

# 10" Dual Port V-6

Flanged CL 150 – 600



10" Dual Port V-6 Flowgrid® Valve with Series 20 Pilot

### SECTIONAL VIEW

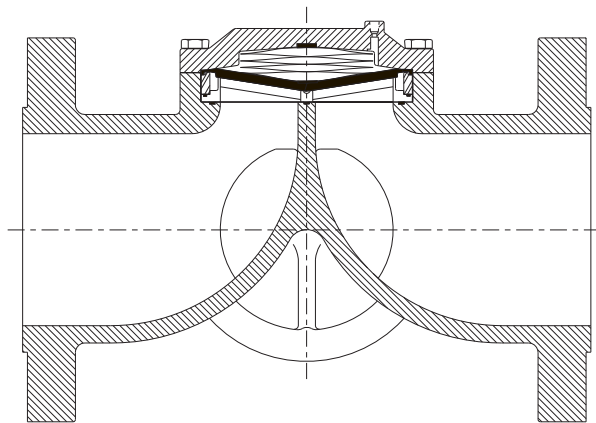

### OVERPRESSURE PROTECTION

The Flowgrid® Valve is bi-directional and has a full ANSI rating on both the inlet and outlet. Overpressure protection is required only if the pressure can exceed the flange or body rating.

The pilots, like most regulators, may have an outlet pressure rating lower than the inlet pressure rating. If this is the case then some external form of overpressure protection must be provided for the pilot.

Anytime the Flowgrid® valve or pilot system is exposed to pressure in excess of its rating it should be inspected for damage.

The 10" Dual Port V-6 Flowgrid® Valve is an economical and easy to maintain pilot operated valve for both gas and liquid applications. The valve can be used with dual pilots for redundant control (acts as two regulators in parallel), but is primarily a large capacity valve that can be maintained by one person. The ports are mounted at 45 degree angles for easy in line maintenance. The low profile makes it ideal for skid mounted, vault, and enclosure installations.

### SPECIFICATIONS

<b>Size</b>	10"
<b>Body Style</b>	Dual Port (6")
<b>End Connections</b>	10" CL150, 300, 600 Flanged
<b>Temperature</b>	Working -20°F to 150°F Emergency -40°F to 175°F
<b>Max. Operating Differential</b>	800 psi
<b>Max. Emergency Differential</b>	1000 psi
<b>Min. Differential</b>	Refer to graph on page 2
<b>Cracking Differential</b>	Refer to graph on page 2
<b>Max. Inlet Pressure</b>	1480 psig*
<b>Outlet Pressure Range</b>	Limited By Pilot
<b>Flow Direction</b>	Bi-Directional**
<b>Body Taps</b>	Four 1/4" - 18NPT

\* Limited by pilot or flange rating

\*\* Reverse flow by changing pilot connections and reversing spring case

### MATERIALS OF CONSTRUCTION

<b>Body &amp; Spring Case</b>	ASTM A 216 GR WCB Carbon Steel
<b>Throttle Plate</b>	17 - 4PH Stainless Steel
<b>Diaphragm</b>	Nitrile/Nylon*
<b>O-Ring &amp; Seals</b>	Nitrile
<b>Bolting</b>	ASTM A 193 GR B-7 or Equal
<b>Spring</b>	301 Stainless Steel

\* Refer to diaphragm selection chart on page 2

### STOCK NUMBERS

10" Dual Port Valve	Stock #	Weight
150# Flange	FG-57	590 lbs.
300# Flange	FG-58	670 lbs.
600# Flange	FG-59	900 lbs.

## DIMENSIONS

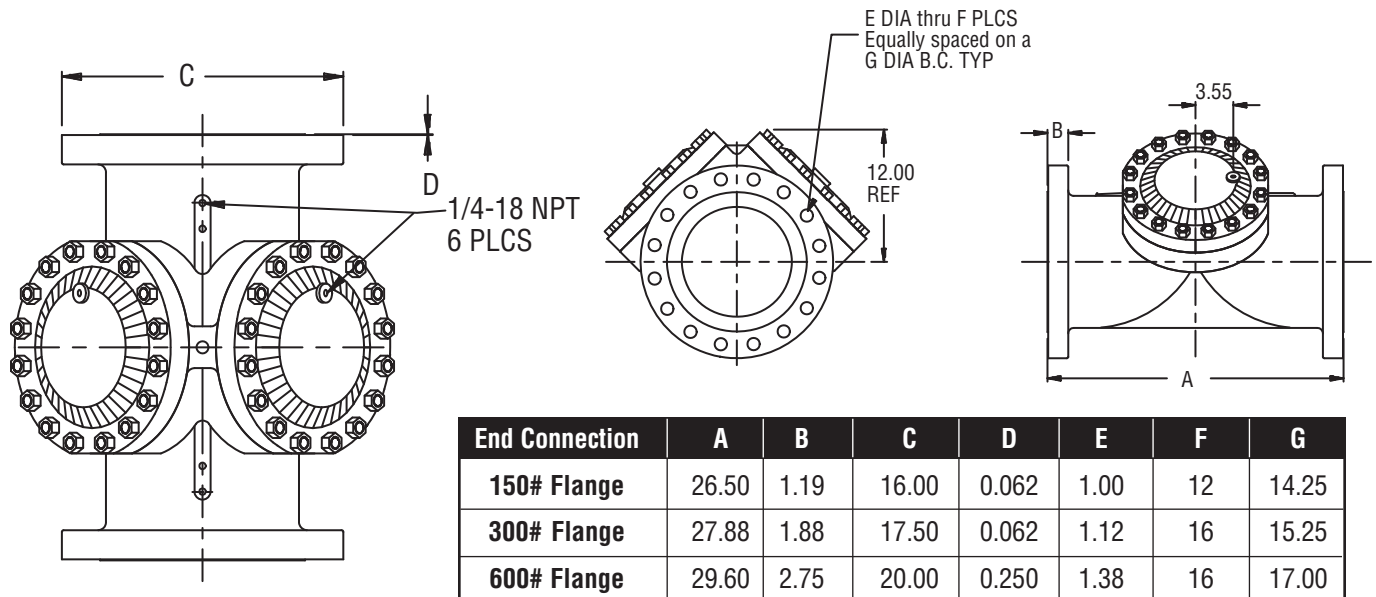

## FLOW COEFFICIENTS AND CONSTANTS

10" Dual Port Valve				Swage Factor	
Percent Capacity	Cv	C1	Cg	1.5:1	2:1
100%	650	33	22000	1.00	0.99
75%	550	30	16500	1.00	0.99
50%	472	28	13200	1.00	0.99
35%	290	27	7830	1.00	1.00

**NOTE:** Allow a 5% factor of safety when calculating relief capacity

## MINIMUM PRESSURE DIFFERENTIAL VS. CAPACITY

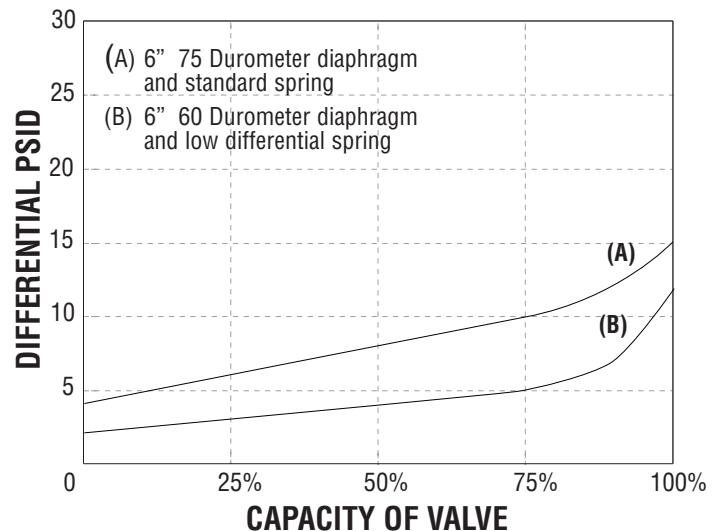

## DIAPHRAGM SELECTION

Compound	Temp. Range (Degrees F)	Maximum Differential	Characteristics	Recommended Applications
75 Duro	-20 to 150	1000 psid	Best All Around Material	60 psid to Max. Differential
60 Duro	-25 to 150	300 psid	Best Shutoff at Low Differential Pressure	Low Differential (100 psid or less) or Low Temperature
80 Duro High ACN	-5 to 175	1000 psid	Higher Abrasion and Swelling Resistance	High Differential (400 psid or higher) or Abrasive Conditions with Distillates
80 Duro Low ACN	-20 to 150	1000 psid	Higher Abrasion Resistance and Low Temperature Flexibility	High Differential (400 psid or higher) or Abrasive Conditions at Low Temperatures

### Mooney

### Dresser, Inc.

2822 S. 1030 W.

Salt Lake City, Utah 84119

Phone: 801.487.2225 Fax: 801.487.2587

www.mooneycontrols.com



www.dresser.com