Model 441-X57

High Pressure Regulators with Roll-out Diaphragm



441-X57 High Pressure Regulators

Features

Simple Design --assures you dependable regulation, trouble free operation, fast response, no pilot freezing, no pilot maintenance.

Standard Face to Face Dimensions

Standardized "441" Bodies & Inner Valve Assemblies--easy maintenance--parts are interchangeable with other 441 models.

Simplified Valve Adjustment--easy to adjust for tight lock-up --accurate.

Molded Polyurethane Soft Seats--positive tight shut-off--high erosion resistance--will not blow out.

O-Ring Stem Seal--with removable anti-friction bushing.

Bushing Guided Inner Valve--accurate stem alignment and valve seating

Side Inspection Plates--both sides of body--quickly removable.

O-Ring Body Seals--eliminates gaskets on upper and lower body openings and side inspection plates.

Self-Aligning Spring Adjustment--color coded springs.

Flanged Removable Seats (Orifices)--easily changed--no special tools needed.

Spring Ranges	Outlet Pressure		Color of Spring	Nominal Diaphragm Size (I.D.)
	Min.	Max.		
	75 to 100 psi		Red	2 1/2" Diaphragm All Ranges
	100 to 175 psi		Brown	
	150 to 250 psi		Black	

Maximum Inlet Pressure-All Types	Regulator Body Type	441 Body Materials	Maximum Working Pressure of Body	Maximum Inlet Pressure
	Flanged ANSI 250 lb. RF	DUCTILE IRON (ASTM A395-71 gr 60-40-18)	575 psi	575 psi*
	Flanged ANSI 300 lb. RF	CAST STEEL (ASTM A216-70a gr WCB)	720 psi	
	Flanged ANSI 600 lb. RF	CAST STEEL (ASTM A216-70a gr WCB)	1200 psi	

*Maximum Inlet Pressure for 2" and 3" 441-X57 with 1 1/2" reduced valve is 1000 psi (Flanged ANSI 600 lb. only) (See pages 5 and 6)
*Maximum Inlet Pressure for 3" 441-X57 with 2 1/8" valve is 400 psi (All Body Types) (See pages 5 and 6)

Maximum Pressure Differential and Maximum Inlet Pressure for Various Soft-Seated Valve Materials*	Valve Material	Maximum Pressure Differential	Maximum Inlet Pressure
	Buna-N (black, 50 to 55 duro)	250 psi	575 psig
	Polyurethane (red, 65 to 75 duro)	400 psi	720 psig
	Polyurethane (tan, 85 to 95 duro)	600 psi	1200 psig

*The differential and inlet pressures given are only to be used as general guidelines. In all cases, pressures must always remain within the ranges specified in Equimeter literature. For any given regulator, do not exceed the specified maximum pressures.

The maximum temperature for the above materials is 150° F

Viton valve material has a maximum temperature rating of 300° F and a maximum pressure differential of 250 psi.

Pipe Sizes	441-X57 High Pressure Regulators		Temperature Limits
	2"	3"	

Buried Service

The 441-X57 High Pressure Regulator is *not* recommended for buried service.

Periodic Inspection: Regulators are pressure control devices with numerous moving parts subject to wear that is dependent upon particular operating conditions. To assure continuous satisfactory operation, a periodic inspection schedule must be adhered to with the frequency of inspection determined by the severity of service and applicable laws and regulations. **See bulletin RM-1361 for field service instructions.**

The “Roll-Out” Diaphragm



The **441-X57** is unique in a high pressure regulator. It features the same “**Roll-Out**” diaphragm principle that has achieved such remarkable success in the widely used 441-57S and 461-57S Regulators.

The **441-X57** offers pilot performance with spring regulator simplicity. The “**Roll-Out**” diaphragm makes this outstanding performance possible by eliminating that old gremlin-- “**Droop.**”

“**Droop**” means rough regulation, wide fluctuation in pressure control as flow varies. It is the result of spring effect plus diaphragm effect.

The “**Roll-Out**” diaphragm changes this. By eliminating diaphragm effect and neutralizing spring effect, “**droop**” is

reduced to insignificance. The result--smooth, constant pressure regulation. It comes amazingly close to the control performance of the pilot operated regulator.

Figure 1 shows how the “**Roll-Out**” diaphragm works. **Figure 2** shows how close performance comes to that of a pilot operated regulator. And the cutaway picture on page 4 shows how simple it is.

Speed of response is fast. Installation, adjustment and servicing are surprisingly easy. The hazard of shutoff from pilot freeze-up is eliminated. And, to top it off, the ingenious ball-check diaphragm sentry (**Figure 3**, this page) adds yet another feature to a list that makes the **441-X57** truly a remarkable high pressure regulator.

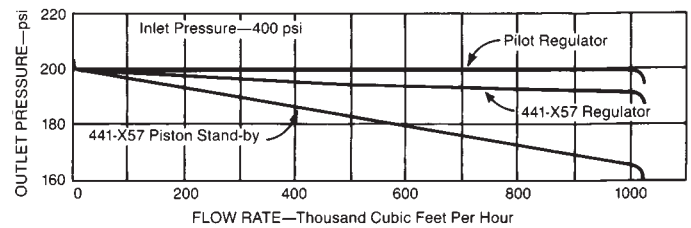
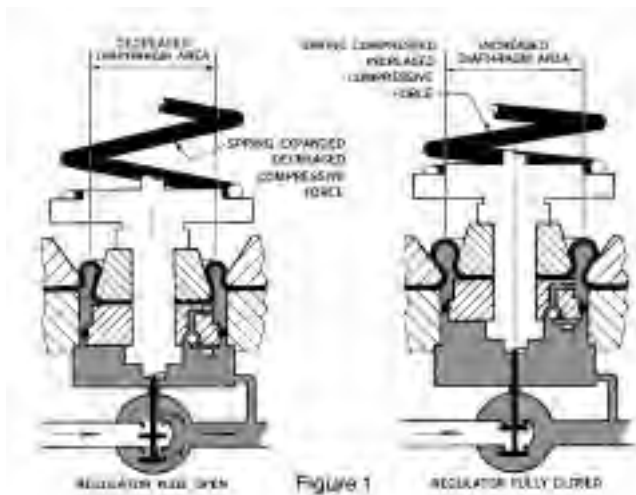

Figure 2

Ball-Check Diaphragm Sentry

The **ball-check diaphragm sentry** is a safety device for keeping the regulator in operation in case of diaphragm failure.

Referring to **Figure 3**, this is how it works:

1. O-ring piston **A** holds the Roll-Out diaphragm in correct alignment during normal operation.
2. Ball-check **B** is normally open to put outlet pressure against the Roll-Out diaphragm.
3. If a break should occur in the diaphragm, outlet pressure gas instantly begins to escape through the break and out the vent to atmosphere. This escaping gas flow immediately closes **B**. With **B** closed, outlet pressure is trapped beneath O-ring piston **A**, which then becomes a substitute for the diaphragm. With **A** as a substitute for the diaphragm, the regulator continues to operate.
4. The closing of **B** also prevents the diaphragm break from allowing gas to escape through the vent.

5. Regulation with the O-ring piston will show increased deviation from set point. This deviation is the warning that a failure has occurred.

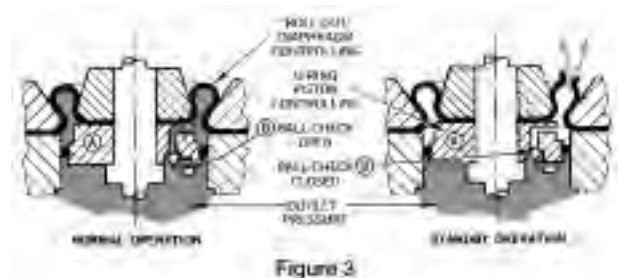

Construction and Design Features

441-X57 "Roll-Out" Diaphragm Regulator

Large Capacity

- for
- High Pressure Regulator Sets
 - Gas Distribution Systems
 - Town Border Stations
 - Transmission Systems
 - Monitoring
 - High Pressure Industrial Applications

X57 "Roll-Out" Diaphragm

(Patented)
See Page 3

Anti-Friction Bushing

Inlet Pressures and Capacities

See Pages 5 & 6

Heavy-Duty Construction

Weather-proof
Watertight
For Indoor
or Outdoor
Installations

Ball-Check Diaphragm Sentry

(Patented)
See Page 3

Inspection Plates

On both sides of the body
Quickly removable
provide easy inspection and
servicing of the inner valve.

Outlet Pressure Range

75 to 250 psi
Note: For outlets of
3 to 100 psi, see Model
441-57S. (Bulletin R 1360)

Balanced Valve

**Double Seat
Soft Seats**
also available--
Reduced Size Valves
V-Port Valves
Hard Seats

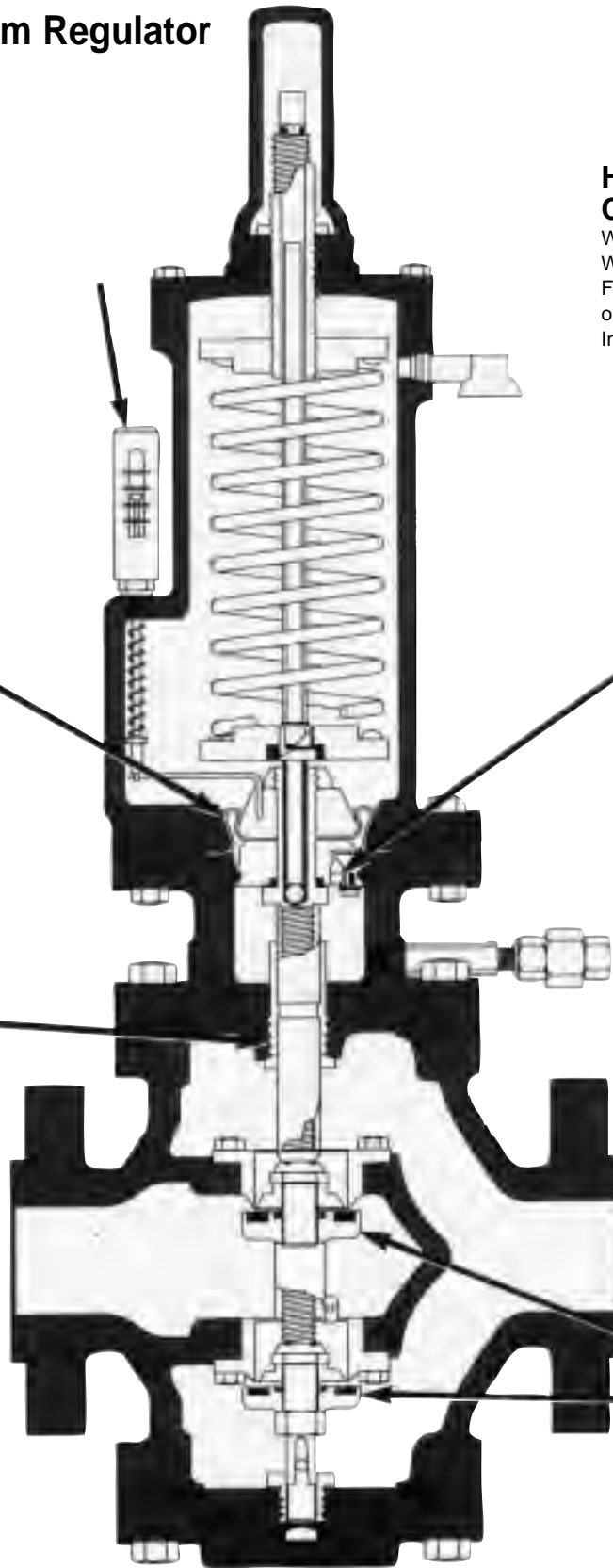

441-X57 Capacity Tables

Capacity 441-X57 in 1000 SCFH of Natural Gas (0.6 Specific Gravity--14.65 psia--60° F)

INLET PRESSURE psi	OUTLET PRESSURE psi	2" 441-X57		3" 441-X57		
		1 ³ / ₄ " Valve	1 ¹ / ₂ " Reduced Valve	2 ¹ / ₈ " Valve	1 ³ / ₄ " Reduced Valve	1 ¹ / ₂ " Reduced Valve
80	75	115	90.3	187	140	90.3
85	75	163	127	265	198	127
	80	118	92.8	193	144	92.8
90	75	200	156	325	243	156
	80	167	131	273	203	131
	85	121	95.3	198	147	95.3
100	75	258	202	420	313	202
	80	237	185	386	288	185
	85	210	165	343	256	165
	90	176	138	287	214	138
110	75	305	239	497	371	239
	80	290	227	473	353	227
	90	249	195	406	303	195
	100	184	144	300	224	144
120	75	346	271	563	421	271
	80	335	262	546	407	262
	90	305	239	497	371	239
	100	260	204	425	317	204
	110	192	150	313	234	150
140	75	415	325	677	506	325
	80	410	321	669	500	321
	90	394	308	642	480	308
	100	369	289	601	448	289
	120	282	221	460	344	221
160	80 & Less	474	371	772	576	371
	90	466	365	760	567	365
	100	451	354	736	549	354
	120	400	313	651	486	313
	140	303	237	493	368	237
180	90 & Less	528	414	862	643	414
	100	521	408	850	634	408
	120	489	383	798	595	383
	140	428	335	698	521	335
	160	322	252	524	391	252
200	100 & Less	583	457	950	710	457
	120	565	443	921	688	443
	140	524	411	855	638	411
	160	455	356	742	554	356
	180	340	266	554	413	266
225	110 & Less	653	511	1064	794	511
	120	648	507	1055	788	507
	140	624	489	1018	760	489
	160	580	454	946	706	454
	180	510	400	831	620	400
250	200	399	312	650	485	312
	125 & Less	721	565	1175	877	565
	140	710	556	1158	864	556
	160	683	535	1113	831	535
	180	636	498	1036	773	498
250	200	564	442	920	686	442
	225	421	330	687	513	330

NOTE: The above performance data is based on normal testing at 70° F flowing temperature. Changes in performance can occur at extreme low flowing temperatures.

441-X57 Capacity Tables

INLET PRESSURE psi	OUTLET PRESSURE psi	2" 441-X57		3" 441-X57		
		1 ³ / ₄ " Valve	1 ¹ / ₂ " Reduced Valve	2 ¹ / ₈ " Valve	1 ³ / ₄ " Reduced Valve	1 ¹ / ₂ " Reduced Valve
275	140 & Less	787	616	1283	957	616
	160	772	605	1258	940	605
	180	741	580	1207	901	580
	200	691	541	1126	841	541
	225	596	467	972	725	467
	250	443	347	722	539	347
300	150 & Less	857	671	1397	1043	671
	175	839	657	1367	1020	657
	200	798	625	1300	971	625
	225	730	572	1190	888	572
	250	626	491	1021	762	491
325	165 & Less	923	723	1505	1124	723
	180	915	717	1491	1113	717
	200	892	699	1454	1085	699
	225	843	660	1374	1026	660
	250	767	601	1251	934	601
350	180 & Less	991	776	1615	1205	776
	200	977	766	1593	1189	766
	225	943	739	1536	1147	739
	250	886	694	1444	1078	694
375	190 & Less	1061	831	1730	1291	831
	225	1033	809	1683	1256	809
	250	991	776	1615	1205	776
400	200 & Less	1130	885	1841	1374	885
	225	1116	874	1818	1357	874
	250	1085	850	1769	1320	850
425	215 & Less	1198	938	--	1457	938
	250	1172	918	--	1426	918
450	230 & Less	1266	992	--	1540	992
	250	1253	982	--	1525	982
475	250 & Less	1330	1041	--	1617	1041
500	250 & Less	1402	1098	--	1706	1098
575	250 & Less	1606	1258	--	1954	1258
800	250 & Less	--	1738	--	--	1738
1000	250 & Less	--	2165	--	--	2165
"K" Factors Standard Valves		5450	4270	8880	6630	4270
"K" Factors V-Port Valves		5260	4160	8440	6390	4160
For V-Port Valves Multiply Table Values By		.965	.974	.950	.964	.974

1. Last capacity figure (**bold type**) for each column is capacity at **maximum inlet pressure**.
2. Size each regulator on the basis of the **minimum expected inlet pressure** and the **maximum required outlet pressure**.
3. For **best performance** of the Model 441-X57, use full table capacity values.
4. For **smaller capacities** see Model 461-X57 (Bulletin R 1332).

NOTE: The above performance data is based on normal testing at 70° F flowing temperature. Changes in performance can occur at extreme low flowing temperatures.

Back Pressure Valves and Relief Valves



Where inlet pressure control is required, as with a back pressure valve or relief valve, use the Model 441-X57R.

The 441-X57R is the same as the 441-X57 except that the inner valve is reversed, the body is turned around, and the control line is arranged for connection to the inlet side (upstream).

The adjustment range is 75 to 250 psi.

Use the table on pages 5 and 6 for capacities.

Pipe sizes and bodies are those given on page 2.

For additional information on the Model 441-X57R, please contact your Equimeter Sales Office.

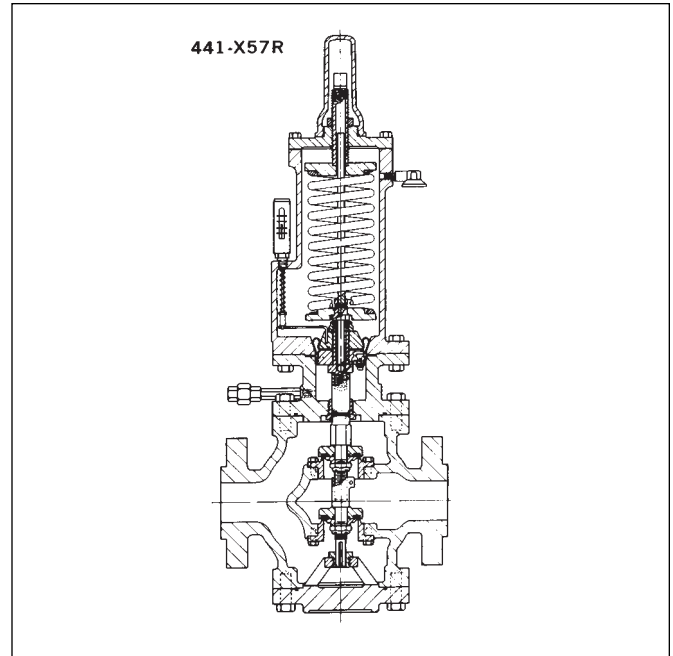

Maximum Emergency Pressures

The following are the maximum pressures which the regulator body may be subjected to under abnormal conditions without causing internal damage:

- Ductile Iron Body Maximum Inlet Pressure + 60 psi
- Cast Steel Body Maximum Inlet Pressure + 100 psi

If body pressure exceeds the above values the regulator must be removed from service and inspected. Damaged or otherwise unsatisfactory parts must be repaired or replaced before returning the regulator to service.

The maximum pressure which the diaphragm may be subjected to under abnormal conditions without causing internal damage

is set-point plus 50 psi. If the pressure on the diaphragm exceeds set-point by more than 50 psi, the regulator must be removed from service and inspected. Damaged or otherwise unsatisfactory parts must be repaired or replaced before returning the regulator to service. The set-point is the outlet pressure the regulator is adjusted to deliver.

The maximum pressure that can be safely contained by the diaphragm case is 350 psi. Safely contained means no leakage and no bursting.

Before using any of the above data, make sure this entire section is clearly understood.

Overpressurization Protection

Protect the downstream piping system and the regulator's low pressure chambers against overpressurization due to possible regulator malfunction or failure to achieve

complete lockup. The allowable outlet pressure is the lowest of the maximum pressures permitted by federal codes, state codes, Equimeter Bulletin RDS-1498, or other

applicable standards. The method of protection can be a relief valve, monitor regulator, shutoff device, or similar mechanism.

Caution: It is the user's responsibility to assure that all regulator vents and/or vent lines exhaust to a non-hazardous location away from any potential sources of ignition. Refer to Equimeter Bulletin RM-1361 for more detailed information.

Monitoring

The Model 441-X57 is also excellent for use as a monitor: a stand-by regulator mounted in series which assumes control if a failure in the operating regulator permits the outlet pressure to rise above its set point.

The 411-X57 has a fast rate of response and, therefore, will take control quickly in case of emergency. It requires no changes or modifications when used for monitoring. Its simple design and rugged construction make it an exceptionally dependable regulator, and its control accuracy and freedom from "droop" mean that it will provide excellent regulation if an emergency calls it into operation.

Two monitor set arrangements are shown in the sketches below. The first shows a set in which the operating regulator and the monitor are both Model 441-X57. This makes an unusually neat and compact installation.

The 441-X57 is also used for monitoring other types of regulators. This is shown in the second sketch. It is excellent for monitoring pilot operated regulators.

Both sketches show the monitor in the downstream position. When installed this way, the 441-X57 is usually set for an outlet pressure 4 to 6 psi higher than the operating regulator and thus is wide open during normal operation.

The monitor can also be located upstream, and with this arrangement the 441-X57 is usually set for an outlet somewhat higher than the above.

Shutoff and bypass valving varies with individual practices and requirements. In general, however, the sketch "Typical Installations" (on page 10) can be used as a guide for the arrangement of these valves.

When identical 441-X57 Regulators are used for both the operating regulator and the monitor, **the total maximum capacity** through both may be figured as 70 percent of the capacity of one of them alone. This applies with the monitor located either downstream or upstream.

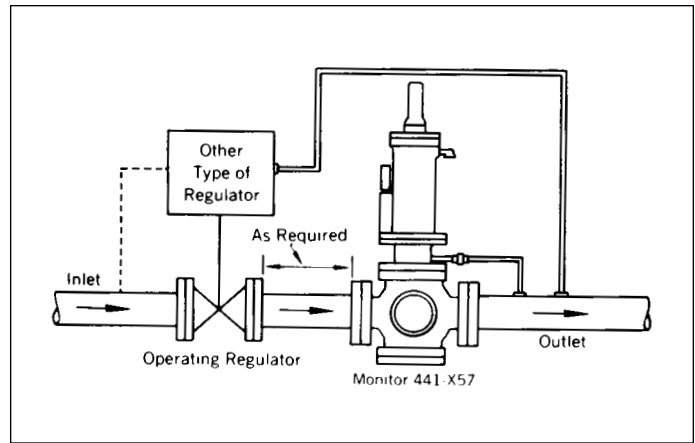
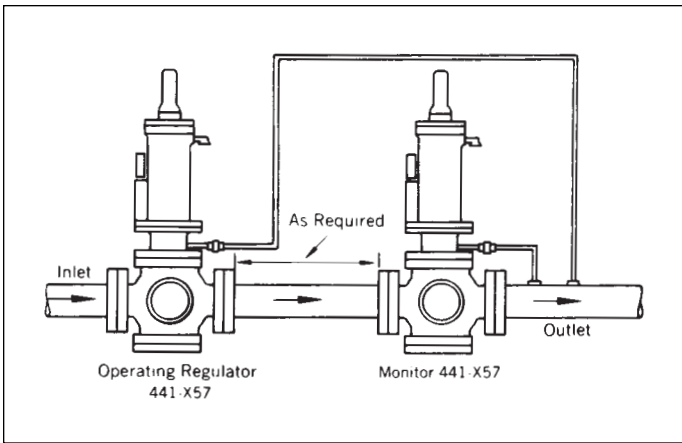

Other Large Capacity Regulators in the "441" Family

Model 441-S low pressure regulators (Bulletin R 1350).
 Model 441-57S "Roll-Out" diaphragm regulators for outlets of 3 to 100 psi. (Bulletin R 1360)
 Model 441-VPC pilot operated regulators for low, medium, and high pressures (Bulletin R 1370)

Metrication

Use the following for metric conversions:

Std. Meters³/Hr. x 35.31 = Std. Ft.³/Hr. (SCFH)
 Std. Ft.³/Hr. (SCFH) x 0.0283 = Std. Meters³/Hr.

Kilograms/centimeter² (Kg/cm²) x 14.22 = psi
 psi x 0.0703 = Kilograms/centimeter² (Kg/cm²)

Kilo Pascals (KPa) x 0.145 = psi
 psi x 6.90 = Kilo Pascals (KPa)

Bars x 14.50 = psi
 psi x .0689 = Bars

Caution: Turn gas on slowly. If an outlet stop valve is used, it should be opened first. Do not overload the diaphragm with a sudden surge of inlet pressure. Monitor the outlet pressure during start-up to prevent an outlet pressure overload. **Refer to RM-1361 for more detailed start-up procedures.**

Dimensions

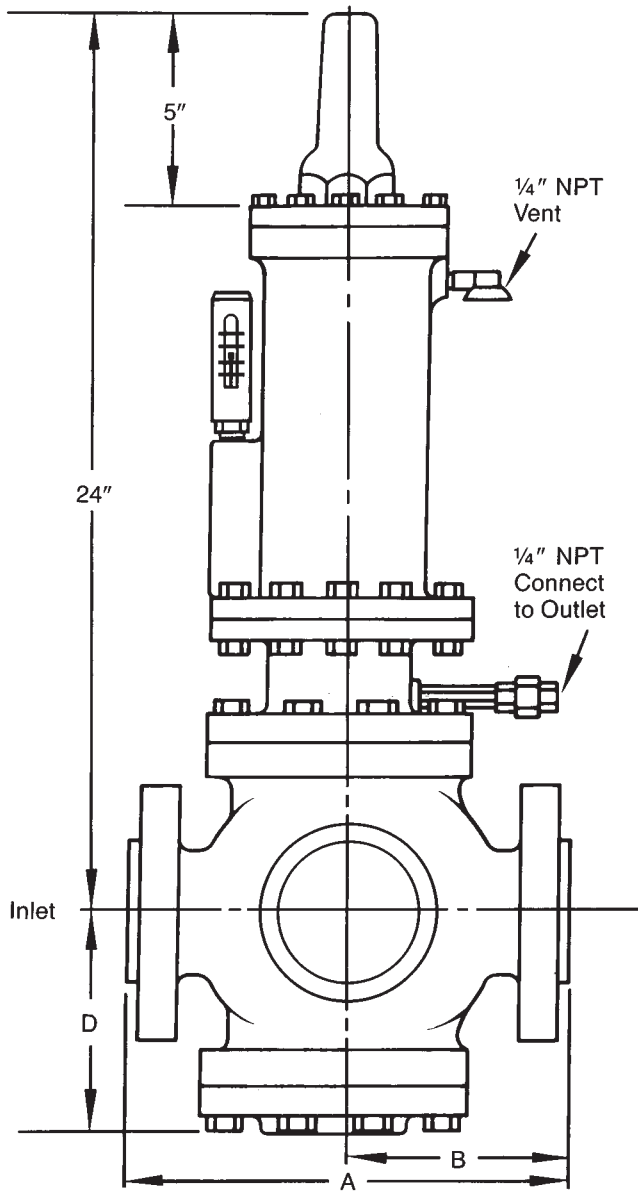

Regular Body Type		Pipe Size	
		Flanged ANSI	
		2"	3"
250 lb. Ductile Iron or 300 Lb. Steel	A	10	12 1/2
	B	5 9/19	6 1/2
600 lb. Steel	A	11 1/4	13 1/4
	B	5 15/16	6 7/8
Shipping Weight, Lbs.		140	180

Typical Installation

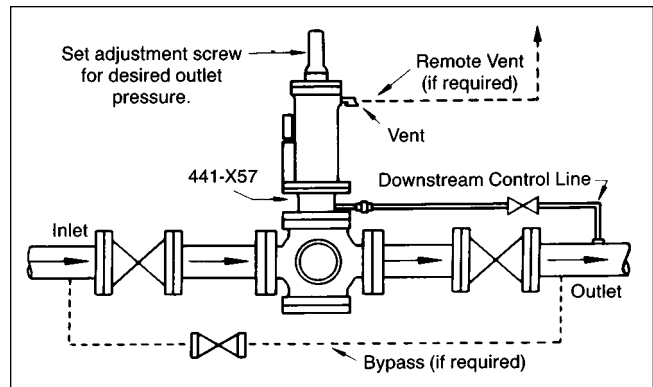



Equimeter produces a broad product line of Gas Pressure Regulators which are widely used throughout the natural gas industry. These regulators are also suitable for non-corrosive industrial gas applications such as propane, butane, air,

nitrogen, dry CO₂, etc. For additional detailed information on a particular model, please request the indicated bulletin from the local Equimeter sales office.

Multi-Purpose Service Regulators

Model 143-80
 Bulletin: R-1301
 3/4", 1", 1 1/4" pipe size
 Inlet pressuresto 125 psi
 Outlet pressures3 1/2" w.c. to 6 psi
 Capacity to 2000 CFH
 Available with straight-through body.
 Also available: internal relief valve and low pressure cut-off.

Model 143-6
 Bulletin: R-1303
 3/4", 1", 1 1/4" pipe size
 Inlet pressuresto 125 psi
 Outlet pressures3 1/2" w.c. to 6 psi
 Capacity to 2000 CFH
 Available with 90° angle or straight-through body.
 Also available: internal relief valve and low pressure cut-off.

Industrial Service Regulators

Models 243-8, 243-12, 243-8HP
 Bulletin: R-1306
 1 1/4", 1 1/2", and 2" pipe size
 Inlet pressuresto 125 psi
 Outlet pressures3 1/2" w.c. to 10 psi
 Capacity to 25,000 CFH
 Also available: internal relief valve, low pressure cut-off, external control line, back pressure regulator, relief valve, vacuum regulator and vacuum breaker.

Industrial Field Regulators

For intermediate to high pressure applications. Ideal on pipeline taps servicing plants and buildings. Appropriate for double stage reduction ahead of service regulators, and for high pressure burners and compressed air systems.

046
 Bulletin: R-1312
 3/4", 1" and 1 1/4" pipe size
 Inlet pressuresto 1000 psi
 Outlet pressures3 to 200 psi
 Capacity to 40,000 SCFH
 Pressure loaded version and internal relief valve also available.

141A
 Bulletin: R-1311
 2" pipe size
 Inlet pressuresto 1500 psi
 Outlet pressures5 to 400 psi
 Capacity to 55,000 SCFH

Pilot Loaded Regulators

For intermediate and high-pressure applications requiring precise pressure reduction with minimal droop. Ideal for standard and high capacity flows on burners, driers, dehydrators and compressor line. Appropriate for fixed factor billing.

243-RPC
 Bulletin: R-1343
 1 1/4", 1 1/2" and 2" pipe size
 Inlet pressuresto 150 psi
 Outlet pressures3 1/2" w.c. to 35 psi
 Capacity to 76,000 SCFH

1100
 Bulletin: R-1341
 Pipe size: 2" (screwed or flanged)
 Inlet pressuresto 400 psi
 Outlet pressures3" w.c. to 100 psi
 Capacity to 414,000 SCFH

1200
 Bulletin: R-1342
 Pipe Size: 2" (flanged)
 Inlet pressuresto 1200 psi
 Outlet pressures20 to 600 psi
 Capacity to 789,000 SCFH



805 Liberty Boulevard

P.O. Box 528

DuBois, PA 15801

814-375-8875

Fax 814-375-8460

Authorized Distributor

All products purchased and services performed are subject to Sensus' terms of sale, available at either; <http://na.sensus.com/TC/TermsConditions.pdf> or 1-800-METER-IT. Sensus reserves the right to modify these terms and conditions in its own discretion without notice to the customer.

This document is for informational purposes only, and SENSUS MAKES NO EXPRESS WARRANTIES IN THIS DOCUMENT. FURTHERMORE, THERE ARE NO IMPLIED WARRANTIES, INCLUDING WITHOUT LIMITATION, WARRANTIES AS TO FITNESS FOR A PARTICULAR PURPOSE AND MERCHANTABILITY. ANY USE OF THE PRODUCTS THAT IS NOT SPECIFICALLY PERMITTED HEREIN IS PROHIBITED.