



A member of the BTR Group

# Installation and Maintenance Instructions

## 2" and 3" TPL-9 Turbo-Meters

### Introduction

Equimeter Turbo-Meters are designed for the measurement of gas in the vapor stage. Proper application and routine maintenance will result in many years of useful service life. *No gas meter of any type can measure gas accurately if it is subjected to solid "slugs" of liquid in the line.*

The following instructions are in general conformance with the recommendations contained in American Gas Association, Gas Measurement Committee Report #7, "Measurement of Gas by Turbine Meters"; (AGA Catalog No. XQ0580).

### On Receipt

Carefully examine the shipping container for any external damage prior to unpacking. Any evident damage should be reported to the carrier.

*Be careful to retain all documents shipped with the meter since these are required for meter records.*

After unpacking the meter, examine it for compliance with your ordering specifications. Report any deviations to your Equimeter representative.

### Product Specifications

Equimeter TPL-9 Turbo-Meter flange dimensions conform to ANSI B 16.5 Standards.

All TPL-9 Turbo-Meters are hydrostatically tested at 1.5 times the maximum rated working pressure indicated on the meter body badge. The maximum rated working pressure stamped on the meter body badge **MUST NOT** be exceeded.

Standard construction Equimeter steel body Turbo-Meters will operate over a flowing gas temperature range of  $-20^{\circ}\text{F}$  to  $+165^{\circ}\text{F}$  ( $-28.9^{\circ}\text{C}$  to  $+74^{\circ}\text{C}$ ). Special construction is available for lower operating temperatures.

### Installation

Turbo-Meters are basically velocity sensing devices which derive volume by sensing the flow rate through the known cross-sectional area of the measuring module housing. Accurate velocity sensing is essential in order to derive accurate volume measurement.

Accessory devices around the Turbo-Meter set can cause a jetting or swirling condition which upsets the normal velocity profile of the flowing gas stream. Extensive tests of Turbo-Meters at various flow rates and pressures have defined the piping installations which result in optimal volume measurement accuracy.

The most common installations are as follows:

**1. Horizontal Mounting**—(inlet in horizontal plane, outlet down) A minimum run of ten (10) pipe diameters of straight pipe is recommended between any flow-altering fitting or accessory and the inlet flange of the TPL-9 Turbo-Meter. This inlet pipe must be the same ID as the meter body. The 10 pipe diameter requirement may be reduced to five pipe diameters if internal straightening vanes are mounted at the inlet end of the meter run piping.

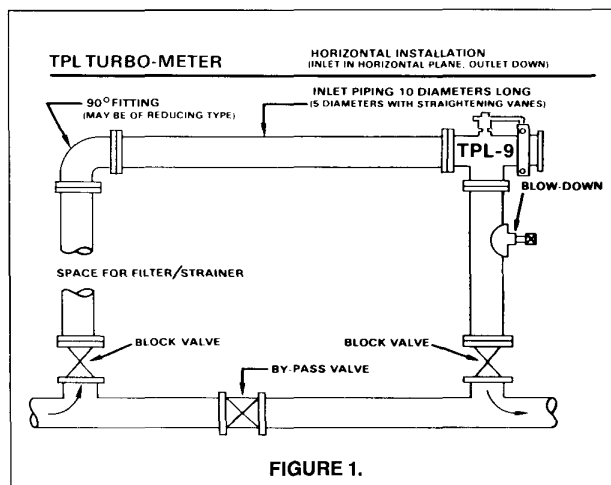

The elbow or tee at the inlet to the horizontal meter run piping can be either full size (2" x 2", 3" x 3") or a reducing type (2" x 3"). The installation of a by-pass line is optional, but is recommended.

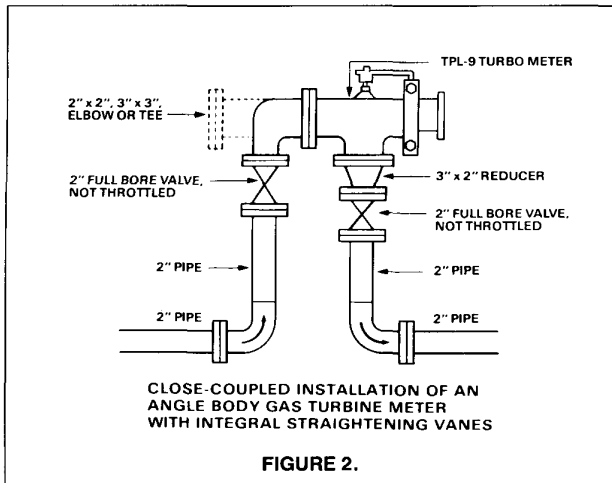

**2. Horizontal, Close-Coupled**—(inlet horizontal, outlet down) Extensive testing of TPL-9 Turbo-Meters at various flow rates and pressures resulted in the evolution of the depicted close-coupled installation which uses either an elbow or tee flanged directly to the meter inlet. As with the previously described set, these fittings may be of the reducing type. (Figure 2)

If desired, a by-pass line with block valve can be mounted across the bottom of this meter set.

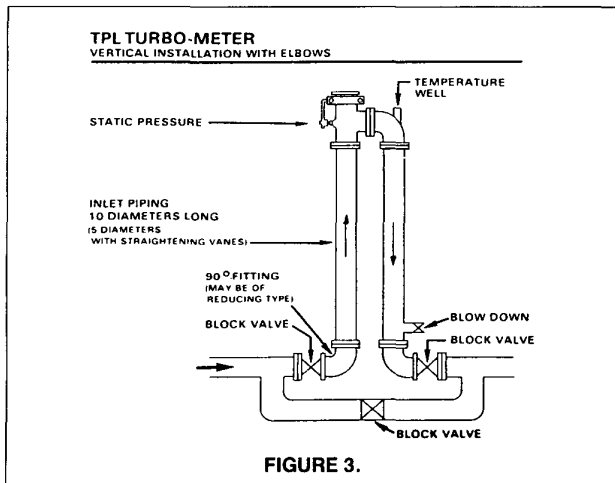

**3. Vertical Mounting**—(inlet down, outlet horizontal) A vertical mounting is recommended where substantial quantities of condensates are present in the line. Also, the vertical installation facilitates the mounting of recording or integrating gauges directly on the meter.

The fitting attached to the meter outlet flange must be full-bore at the flange adjacent to the meter. When a 3" TPL-9 Turbo-Meter is used, this fitting may be of the reducing type (3" x 2").

Again, the installation of the by-pass line with block valve is optional.

**NOTE**

*Where pressure and temperature sensing are required, the meter set must recognize these needs. A pressure tap is located on the top center line of the meter body for sensing static pressure. Temperature connections for either recording or integrating gauges should be located downstream of the meter within two pipe diameters of the meter outlet flange.*

If a bleed-to-line pilot loaded pressure regulator is installed upstream of the meter, the control line must also be attached upstream of the meter. Installation of the control line downstream of the meter amounts to a by-pass which can result in significant volumes of unmeasured gas at elevated pressure.

**Blow-Down**

Provision for a controlled pressure blow-down of the meter run should be made. The blow-down should be located between the downstream side of the turbine meter rotor and the downstream block valve on the meter set (Figure 3). Although Turbo-Meters can be operated at 150% of maximum rated capacity for short periods of time with no adverse effects, over-sized blow-downs can cause speeds greatly in excess of this amount.

For a 3" TPL-9 meter, the blow-down should not exceed 1/2" size. For a 2" TPL-9 meter, the maximum blow-down size is 1/4".

**⚠ DANGER**

METER UNDER PRESSURE  
DEATH OR PERSONAL INJURY  
CAN RESULT IF HALF CLAMPS ARE  
LOOSENED BEFORE PRESSURE IN  
METER IS FULLY RELIEVED



## Safety Interlock Device

These instructions, packed with each Equimeter 2" and 3" TP and TPL Turbo-Meter, caution users to relieve all pressure inside the meter body prior to attempting disassembly of the meter. Additionally metal caution badges are affixed to each of the meter half-clamps warning users to relieve pressure inside the meter before removing the half-clamps. An example of the metal caution badge is shown at the top of this page.

In spite of these warnings and established industry practices, Equimeter has been advised that some users have attempted meter disassembly with pressure inside the meter body.

Thus, the Safety Interlock Device is available for 2" and 3" TP and TPL Turbo-Meters. When installed this device provides an audible warning of pressure inside the meter before disassembly occurs.

New 2" and 3" TPL Turbo-Meters shipped since January 1, 1985, have the Safety Interlock Device installed. Retro-fit kits are available for installation on 2" or 3" TP and TPL Turbo-Meters shipped in prior years. See Parts List MP-1081 for kit part numbers.

### Operation

When installed, the Safety Interlock Device covers the meter half-clamps to prevent access to the half-

clamp bolts while the meter is under pressure. In order to access the half-clamp bolts, it is first necessary to back off the safety relief valve stem, (#3 in drawing) on page 4.

Doing so allows line pressure to be relieved to atmosphere through a restricted  $\frac{1}{16}$ " opening causing a noise, thereby providing a warning to the operator of pressure inside the meter body. The operator then uses the piping system blow-down valve to relieve pressure in the meter body until such time as the noise through the relief valve no longer occurs.

With the relief valve stem backed off, the Safety Interlock Device can be moved toward the meter inlet flange, thereby exposing the half-clamp bolts. When all pressure inside the meter has been relieved, disassembly of the meter can proceed.

Following inspection and maintenance of the meter, the half-clamps and bolts are re-assembled on the meter in the normal manner. Prior to repressuring the meter, the Safety Interlock Device must be repositioned over the half-clamps. When this is done, the relief valve stem can be screwed into its body to provide a gas-tight seal.

Following re-assembly, pressurize the meter and check all joints for leaks prior to leaving the meter site.

*Continued on page 4*

## Description

The Safety Interlock Device was designed for use on Equimeter angle body Turbo-Meters to prevent accidental disassembly of the half-clamps before internal pressure has been fully relieved. The device

was designed with your safety in mind; however, no device can be safer than the user. Therefore, it is important that these instructions be carefully followed and maintained for future reference.

### PART IDENTIFICATION:

ITEM NO.	DESCRIPTION
1	Safety Relief Valve Body
2	1/4" NPT Pipe Plug
3	Safety Relief Valve Stem
4	Interlock Arm
5	Anti-Rattle Set Screw
6	Half Clamp Safety Cover
7	Valve Stem Locking Counter Bore
8	Interlock Arm Slot
9	1/4" to 1/8" Reducer
10	Meter Body Pressure Tap Connection
11	Loctite <sup>®</sup> #277 (Red)
12	Roll Pin
13	Half Clamp

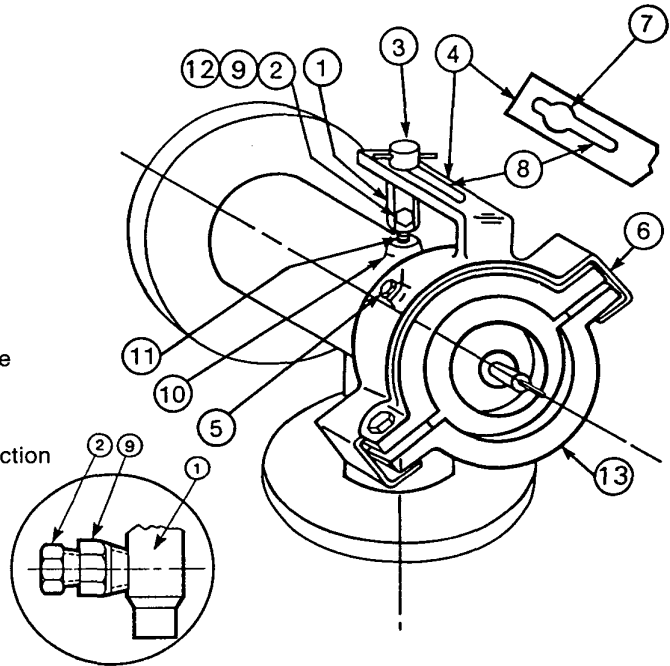

### FIELD KIT ASSEMBLY NO

### TURBO-METER MODEL DESIGNATION\*

00616-677-00000

2" TP-4

00616-677-01000

2" TPL-9

00620-677-00000

3" TPL-9 & TP-9

**NOTE:** Field kits must be ordered for the specific meter model on which they will be installed.



A member of the BTR Group

## Important Instructions

### Equimeter TP and TPL Turbo-Meter Half-Clamp Safety Interlock Device

**Initial Installation:** (For Retrofit Field Kits Only)  
Make sure the model number of your safety device corresponds with the model of meter for intended use. (Model Stamped on Item 4)

- A. **△ DANGER** For field installations. First shut-in the meter by closing inlet and outlet block valves. Then fully relieve line pressure from meter.
- B. Remove pipe plug or connection from pressure tap 10.
- C. Loosen relief valve stem 3 and slide relief valve assembly 1 and 3 to the end of the slot away from counter bore 7. Note that valve stem 3 cannot be completely removed from valve 1.
- D. Apply Loctite™ 11 (as supplied) to threads of valve 1 as a sealant and to prevent removal. (Use only Loctite™ #277 (red)). Align relief valve 1 with pressure tap 10. Place interlock device over body, and tighten relief valve 1 into pressure tap 10.
- E. Pry off old caution badges and stick on new danger badges 12 on both half-clamps 9.
- F. If necessary, loosen the half-clamp retaining bolts and rotate the half-clamps 9 to line up with clamp safety cover 6. Re-tighten half-clamp bolts.
- G. Slide clamp safety cover 6 over the half-clamps 9. It may be necessary to first loosen the anti-rattle set screw 5.
- H. Align locking counter bore 7 with relief valve stem 3. Then tighten down the valve stem 3.
- I. Tighten the anti-rattle set screw 5 to restrain the clamp safety cover 6 during shipment or from line vibrations.
- J. A pressure recording device can be connected to the 1/8" NPT pressure tap 2. This may require a 1/4" to 1/8" NPT reducer (not included).
- K. Check for leaks at all connections.

## Operating Instructions

### Removal Instructions:

- A. **△ DANGER** Shut-in the meter by closing inlet and outlet block valves. Fully relieve line 3 pressure from meter through the system blow-down valve. Then loosen the relief valve stem.
- B. Once pressure has been safely relieved, continue to loosen valve stem 3 until completely out of counterbore 7. Loosen anti-rattle set screw 5, which will allow the interlock arm 4 to slide in the slot 8. Note that valve stem 3 cannot be completely removed from valve 1.
- C. Slide the clamp safety cover 6 to uncover the half-clamps 9. The half-clamp retaining bolts may now be removed.

### Re-Assembly Instructions:

- A. Align half-clamps 9 with clamp safety cover 6 and tighten half-clamp retaining bolts.
- B. Slide interlock arm 4 through slot 8 until the half-clamps 9 are covered and the counter bore 7 lines up with the relief valve stem 3.
- C. Tighten the relief valve stem 3 and tighten the anti-rattle set screw 5.
- D. Check for leaks at all connections.

## Dimensions

Nominal dimensions of Equimeter TPL-9 Turbo-Meters are as follows:

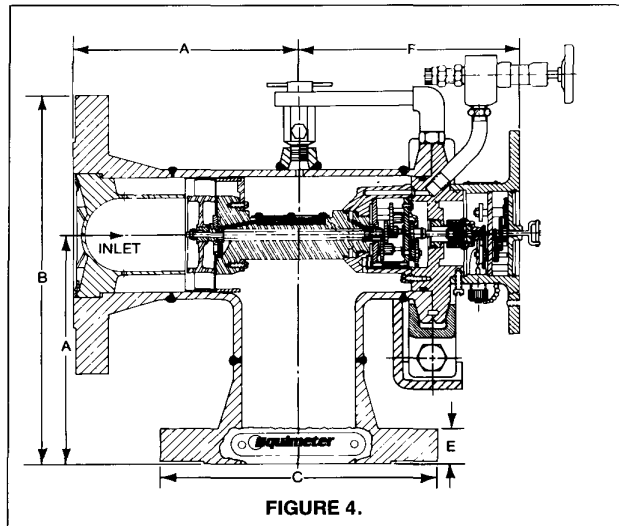

### Dimensions—Inches

	2"—TPL-9			3"—TPL-9		
	ANSI 150	ANSI 300	ANSI 600	ANSI 150	ANSI 300	ANSI 600
A	5 <sup>1</sup> / <sub>16</sub>	5 <sup>5</sup> / <sub>16</sub>	5 <sup>11</sup> / <sub>16</sub>	6 <sup>3</sup> / <sub>16</sub>	6 <sup>9</sup> / <sub>16</sub>	6 <sup>15</sup> / <sub>16</sub>
B	8 <sup>1</sup> / <sub>16</sub>	8 <sup>9</sup> / <sub>16</sub>	8 <sup>15</sup> / <sub>16</sub>	9 <sup>15</sup> / <sub>16</sub>	10 <sup>11</sup> / <sub>16</sub>	11 <sup>1</sup> / <sub>16</sub>
C	6	6 <sup>1</sup> / <sub>2</sub>	6 <sup>1</sup> / <sub>2</sub>	7 <sup>1</sup> / <sub>2</sub>	8 <sup>1</sup> / <sub>4</sub>	8 <sup>1</sup> / <sub>4</sub>
E	<sup>3</sup> / <sub>4</sub>	<sup>7</sup> / <sub>8</sub>	1 <sup>1</sup> / <sub>4</sub>	<sup>15</sup> / <sub>16</sub>	1 <sup>1</sup> / <sub>8</sub>	1 <sup>1</sup> / <sub>2</sub>
F	6 <sup>1</sup> / <sub>2</sub>	6 <sup>1</sup> / <sub>2</sub>	6 <sup>1</sup> / <sub>2</sub>	6 <sup>1</sup> / <sub>16</sub>	6 <sup>1</sup> / <sub>16</sub>	6 <sup>1</sup> / <sub>16</sub>
Weights (lbs.)	35	39	43	45	58	58

## Filters/Strainers

Where excessively dirty gas conditions exist, a filter or strainer should be installed upstream of the Turbo-Meter at the locations shown in the installation drawings.

## Initial Start-up (Refer to Figure 5)

1. Valve C open, Valves A, B and D closed
2. SLOWLY open Valve A
3. When meter stops registering, SLOWLY open Valve B
4. Close Valve C

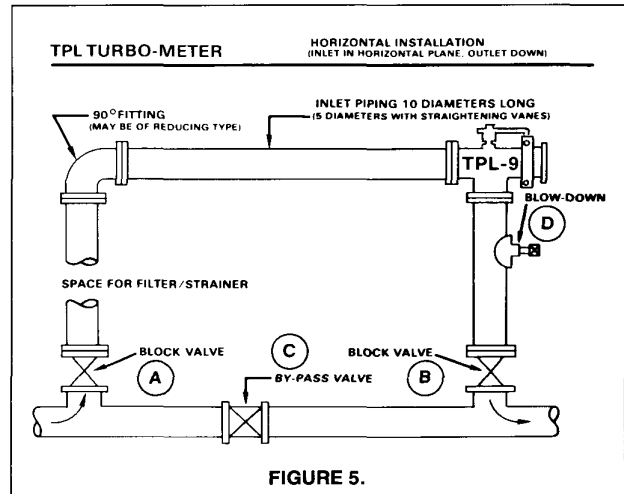

## Shut-Down (Refer to Figure 5)

1. Open Valve C
2. SLOWLY close Valve B
3. SLOWLY close Valve A
4. Carefully open Valve D (Caution—Doing so will relieve meter run line pressure to atmosphere. Do NOT stand in front of flow path.)

### CAUTION

**All pressure in the meter run must be relieved to a non-hazardous location prior to disassembly of the meter.**

## Re-Start

Follow procedure outlined for initial start-up.

### NOTE

**Valves should be operated slowly to prevent shocking the meter. The higher the pressure, the slower the valve operation required.**

On high pressure installations, a valved by-pass around the inlet riser block valve ("A" in Figure 5) is recommended. Usually constructed of <sup>3</sup>/<sub>4</sub>" pipe, with a needle-type valve, the by-pass permits pressurizing of the meter run without damaging the meter.

During the startup, with the meter set valves positioned as in #1 in start-up procedure above, the needle valve is opened and the meter run brought up to the inlet pressure. Once the inlet pressure has been achieved, as indicated by lack of any registration on the meter, the needle valve is closed and Steps #2, #3, and #4 in start-up procedure followed.

**CAUTION**

*Do NOT install the Turbo-Meter before the line has been purged and hydrostatically tested.*

**Lubrication**

The rotor shaft bearings **MUST** be lubricated prior to putting the meter in service. Use the instrument oil shipped with the meter. Two different methods of lubricating the meter are detailed in the following procedures:

The recommended lubrication procedure is the pressure method which provides positive lubrication and flushing of the rotor shaft bearings by use of a manual handgun. An optional gravity feed procedure may be used where handguns are not available.

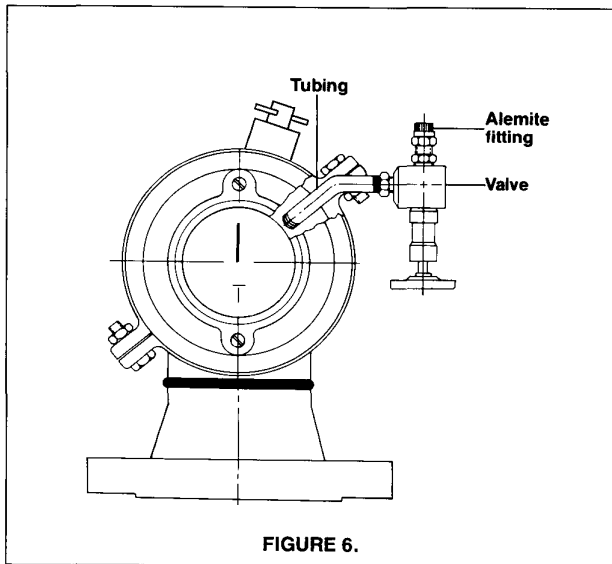

FIGURE 6.

**Lubrication Procedure**

**A. Pressure lubrication:**

- a. Remove protective cap from Alemite #1977 fitting. Open lubrication valve and check for leakage through the ball-check in the Alemite fitting. If the fitting leaks, close the valve and replace the fitting prior to lubricating the meter.
- b. Securely attach the coupler of the handgun to the Alemite fitting on the meter. Hold the pump end of the lubricating gun down to allow oil to fill the pump chamber.

c. Begin pumping the gun lever, observing the pressure gauge while doing so. The gauge will indicate a higher pressure with each stroke until the internal pressure is overcome. When this occurs, the pressure gauge needle will bounce between two points (See Figure 7).

d. THREE pumps of the gun after the internal pressure has been overcome will provide about 3 cc of oil which should be sufficient for lubricating the meter.

e. Remove the gun coupler from the lube fitting of the meter. Again, check for any leakage through the Alemite fitting. Close the lubrication valve and replace the protective cap on the Alemite fitting.

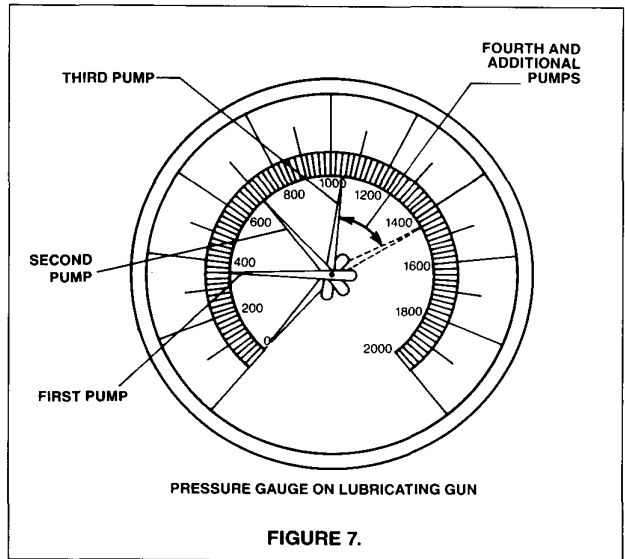

FIGURE 7.

**B. Gravity lubrication:**

- a. Be sure lubrication system valve is securely closed.
- b. Remove Alemite fitting.
- c. Fill inlet of valve with recommended Turbo-Meter oil.
- d. Re-install Alemite fitting securely.
- e. Cycle lubrication system valve full open to full closed three times.
- f. Repeat steps "a" through "e" above.
- g. Leave lubrication system valve closed.



**d** A member of the BTR Group

**CAUTION**

*The lubrication system is subject internally to full line pressure. Follow the procedures as detailed above to prevent blowing gas to the atmosphere. ALWAYS leave the lubricating system valve closed except when actually lubricating the meter. NEVER use the lubrication system to blowdown pressure in the meter. Doing so will force any line contaminants directly into the bearings. NEVER attach static pressure lines from either recording or integrating gauges to the lubrication system.*

**NOTE**

*The Turbo-Meter will not be lubricated unless the check valve in the meter lube fitting is opened. One or two pumps of the gun, after the gun is primed, will open the check valve.*

**Recommended Lubrication Oils**

Equimeter Turbo-Meter oil specifications conform to Military Specifications MIL-L-6085A. Generally, this specification refers to a synthetic, di-ester based lubricating oil with an SAE viscosity number of 5W containing NO PCB's.

Recommended Turbo-Meter lubrication oils and the sources of supply are as follows:

Oil	Source
Chemlube #201	Ultra-Chem Corporation 1400 North Walnut Street Wilmington, Delaware 19899 Telephone: 302/571-8520
Anderol 401-D	Tenneco Chemicals Turner Place Post Office Box 365 Piscataway, New Jersey 08854 Telephone: 201/981-5000

Recommended lubricating oil is available from Equimeter in small plastic bottles and one gallon cans as follows:

- 4 oz. bottle—Equimeter Part Number 006-22-405-01
- One gallon can—Equimeter Part Number 006-22-905-02

**CAUTION**

*When lubricating meters operating at low line pressures, a minimum of 100 psig must be obtained on the gauge to open the check valve in the meter lube fitting.*

**Frequency of Lubrication**

The frequency of lubrication required in order to maintain the rotor shaft bearings in good operating condition is a function of the severity of the service. High pressure and flow rates coupled with dirty gas conditions require more frequent lubrication.

The rotor shaft bearings MUST be lubricated with the recommended oil shipped with the meter prior to putting the meter in service. Subsequent lubrication should be done monthly with the period extended as operating conditions permit.

**Mechanical Readout Mounting**

Mechanical indexes, recording gauges, pressure integrating gauges and both pressure and temperature integrating gauges all can be mounted on TPL-9 Turbo-Meters.

**Handgun**

A lubricating handgun, including a pressure gauge and, importantly, a relief valve, is available from Equimeter as Part Numbers 006-24-400-00 (0-2000 psi) 006-24-400-01 (0-600 psi).



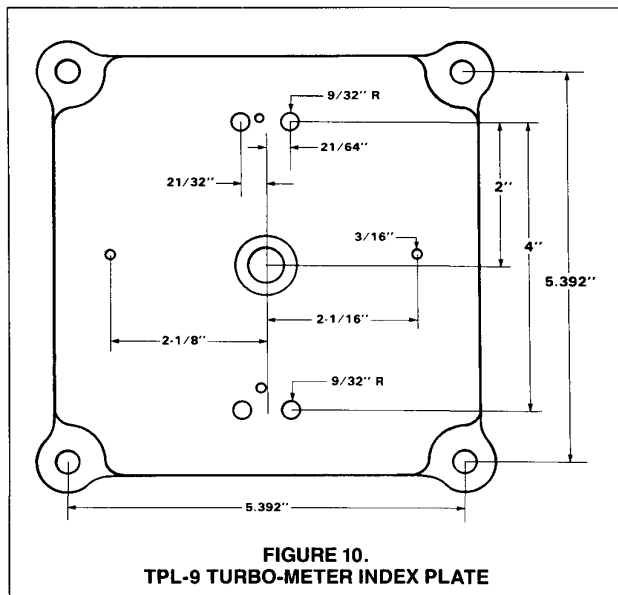

One counter-clockwise 360° revolution of the standard TPL-9 Turbo-Meter output shaft is equal to 100 cubic feet of gas at line conditions. Special construction is available to provide 10 cubic feet per revolution to drive meter indexes only.

For metric meters, the standard construction provides 1.0m<sup>3</sup> per revolution with the special construction providing 0.1m<sup>3</sup> per output shaft revolution.

**CAUTION**

*Be sure the readout device used is matched to the direction of rotation and the value per revolution of the meter output shaft. Failure to correctly match the readout device to the meter will result in significant measurement error and possible damage to the readout device. Adapter plates are available to permit mechanical gauges of other manufacturers to be mounted on Equimeter Turbo-Meters.*

When TPL-9 Turbo-Meters are installed in the horizontal position (Figures 1 and 2), a 90° goose-neck adapter is required to mount recording or integrating gauges in their normal vertical position. This adapter (Figure 11) is available from Equimeter as Part Number 006-22-407-00. As shown, this adapter mounts on the meter index plate.

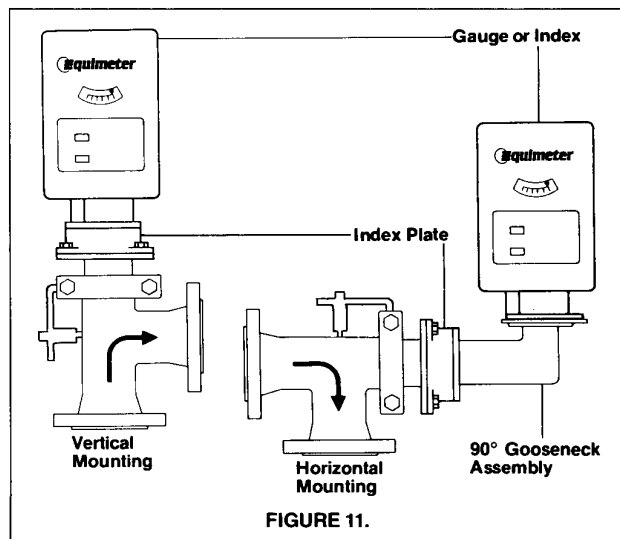

**Pulse Output Options**

The intermediate gear train assembly has two ceramic magnets of the inlet side (Figure 12).

These magnets actuate an optional switching device to produce pulses per predetermined unit of volume at line conditions. The switch used is a glass encapsulated reed switch which is protected by a plastic cover.

The base plate of the intermediate gear assembly contains two slots at 180° from each other. When installed in the meter, one of these slots is fitted over a positioning pin located in the intermediate gear housing casting. To change from one pulse frequency to the other, the intermediate gear assembly is lifted out of its housing, rotated 180°, and reinstalled.

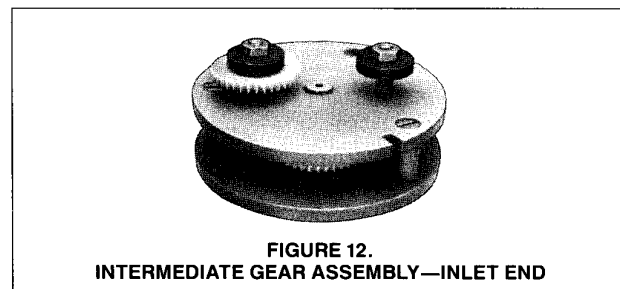

The location of the magnets can be easily ascertained by examining the face plates of the intermediate gear housing and intermediate gear assemblies. The cast iron housing is stamped with the letter "P" adjacent to the gear assembly. The face plate of the gear assembly is stamped with the letters "L" and "H" designating low or high frequency. Thus, if a low frequency pulse is required from a TPL-9 meter, the letter "L" on the gear assembly

is placed adjacent to the letter "P" on the housing face plate. The resulting pulse output will represent one hundred cubic feet at line conditions, (1.0m<sup>3</sup>).

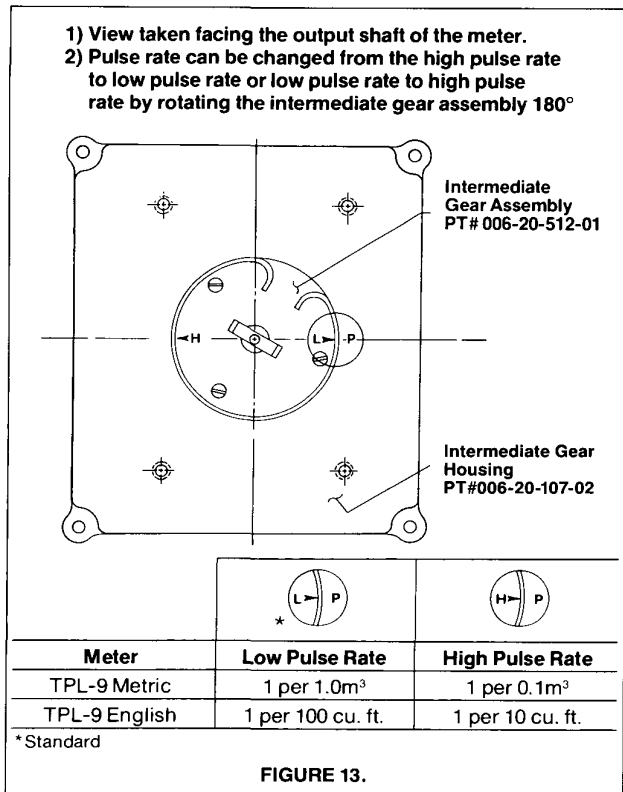

There are actually three optional fixtures available for attachment to the intermediate gear housing casting. When no pulse output is desired, a simple cover plate is placed over the opening in the casting. (Refer to Figure 14, top). Where pulse outputs are desired and a frequent disconnect of wiring is anticipated, a Bendix connector conforming to Military Specification 3106A-10SL-4S is used. (Refer to Figure 14, middle). For semi-permanent installations, an adapter to 1/2" conduit is available. (Refer to Figure 14, bottom).

Customer orders for TPL Turbo-Meters should specify which type of fitting is desired. Field changes from one type of pulser connection to another are simply made since the intermediate gear housing is not subject to line pressure.

## High Speed Pulser Option

Bendix (plug-in) conversion kit—Cu.Ft.  
Part Number: 006-20-522-00  
Bendix (plug-in) conversion kit—Metric  
Part Number: 006-20-522-02

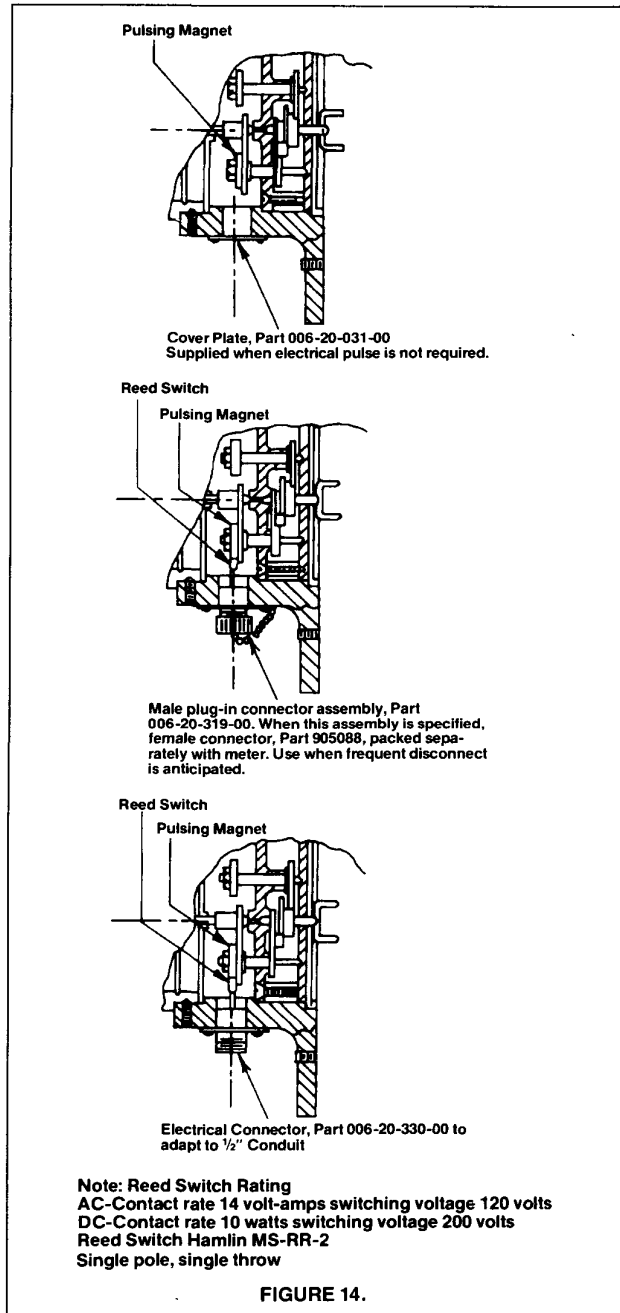

Conduit Connection conversion kit—Cu. Ft.  
Part Number: 006-20-522-01  
Conduit Connection conversion kit—Metric  
Part Number: 006-20-522-03

**CONNECTION DIAGRAM FOR TPL-9 TURBO-METER with HIGH SPEED PULSER and EQUIMETER MPB-II FLOW COMPUTER or ACT-PAK INSTRUMENTS**

**MM-1588-1**

**Diagram 1**

FOR CONNECTION THROUGH CERTIFIED ZENER BARRIER DEVICE RATED 30V OR LESS 90 OHM OR MORE.

NOTE: INSTRUMENTS MUST BE EQUIPPED WITH TPL OPTION TERMINALS

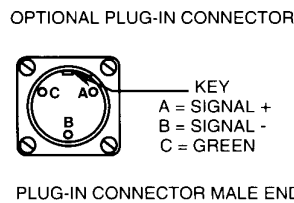
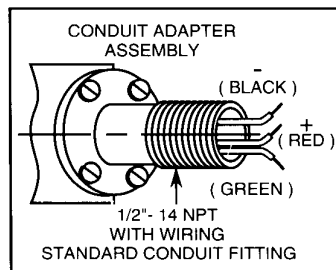
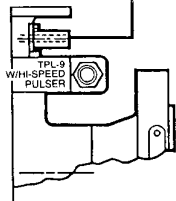
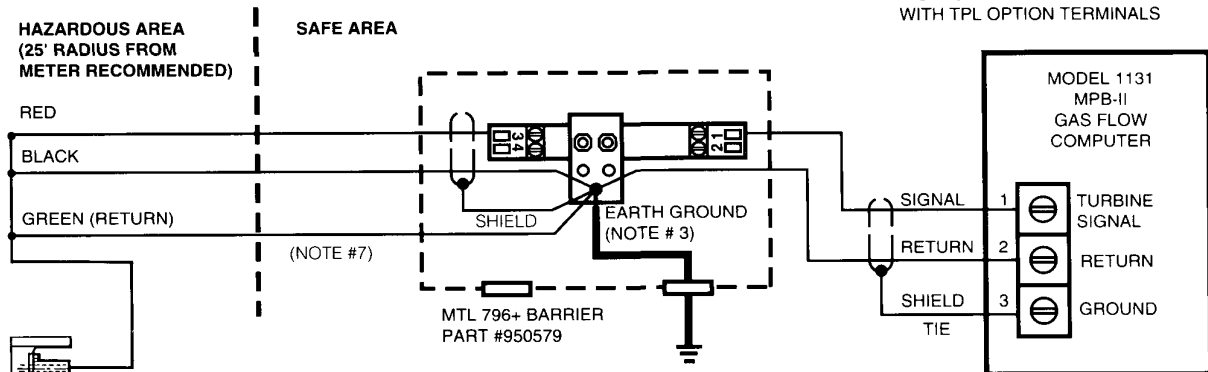

ACT-PAK INSTRUMENTS WITH TPL OPTION

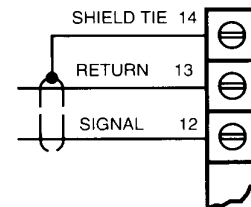

**Barrier Enclosure**

**MT-2 for One or Two Barriers — Part #950580**

**MT-5 for up to Five Barriers Maximum — Part #950581**

Barrier must be installed according to manufacturer's instructions and must comply with applicable local codes in a manner approved by the authority having jurisdiction. Refer to installation instructions packaged with barrier.

- 1 All signal wires connecting the Slot Sensor to the shunt diode safety barriers must be run separately from all other wiring. This is necessary to comply with intrinsic safety guidelines.
- 2 Use 2 conductor #18 twisted shielded cable, Belden 8760 or equivalent. For maximum protection, conduit is recommended.
- 3 Ground bus is connected to earth ground by an insulated #12 wire, or larger if required by local codes. Resistance to ground must be less than one ohm. Local codes may require redundant ground wires (two places).

- 4 Maximum cable length from meter to barrier must be less than 1,000 feet.
- 5 Wiring system shown is applicable for use with Equimeter MPB-II Flow Computer or Equimeter ACT-Pak instruments only. Do not use this diagram for systems incorporating instruments not made by Equimeter.
- 6 See wiring diagram on Equimeter ACT-Pak instruments for detail on terminal connections.
- 7 If meter is isolated, connect green ground wire to earth ground at safety barrier. If meter is not isolated, do not connect green wire to ground.

**NOTE**

Refer to Diagrams 2 and 3 on pages 12 and 13 when connecting to non-Equimeter instruments.

**CONNECTION DIAGRAM FOR TPL-9 TURBO-METER with HIGH SPEED SLOT SENSOR PULSER and NON-EQUIMETER INSTRUMENTATION (120 VAC Supply)**

MM-1571-7

Diagram 2

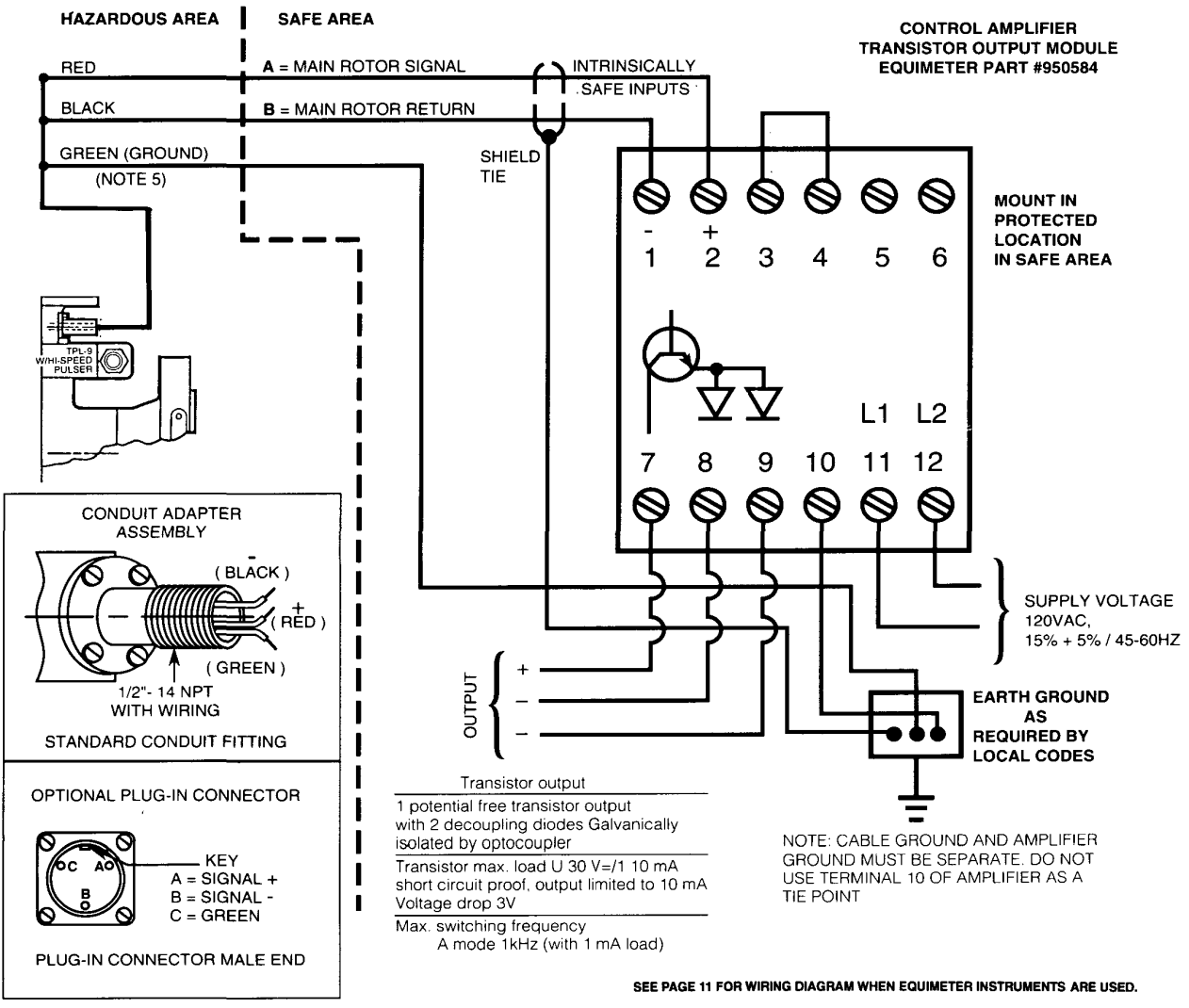

**Control Amplifier Enclosure MTL-UC2 — Part #950583**

Control amplifier must be installed according to manufacturer's instructions, and must comply with applicable local codes in a manner approved by the authority having jurisdiction. Refer to installation instructions packaged with control amplifier.

**1** All signal wires connecting the Slot Sensor to the control and amplifier must be run separately from all other wiring. This is necessary to comply with intrinsic safety guidelines.

- 2** Use 2 conductor #18 twisted shielded cable, Belden 8760 or equivalent. For maximum protection, conduit is recommended.
- 3** Maximum cable length from meter to barrier must be less than 1,000 feet.
- 4** Module IS P.F. Control Amplifier WE77 / EX1-OT or Equimeter Part #950584.
- 5** If meter is isolated, connect wire to earth ground. If meter is not isolated, do not connect green wire to ground.

**CONNECTION DIAGRAM FOR TPL-9 TURBO-METER WITH HIGH SPEED PULSER and NON-EQUIMETER INSTRUMENTATION (24 VDC Supply)**  
**Diagram 3**

MM-1643

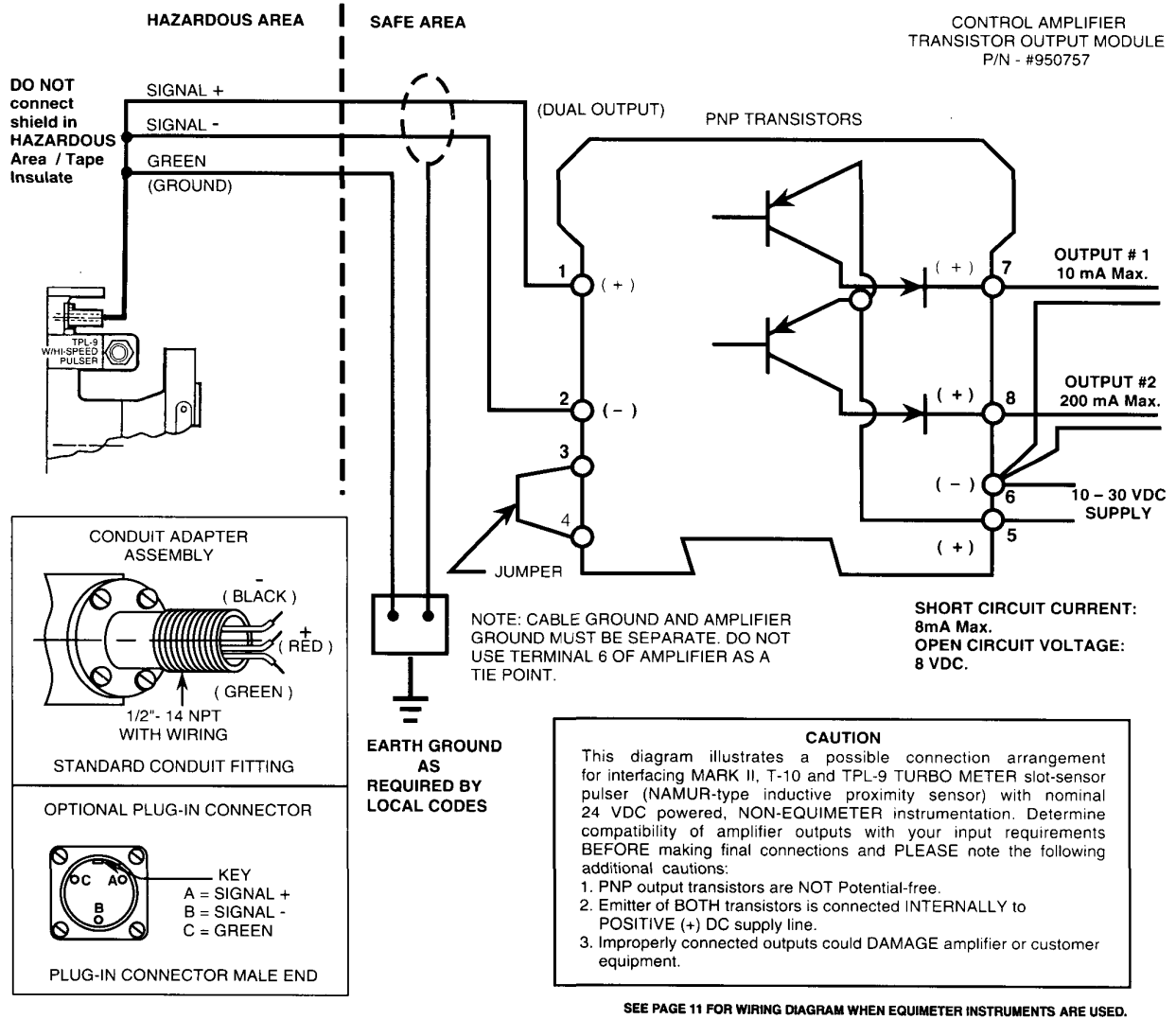

**Control Amplifier Enclosure**  
**MTL-UC2 — Part #950583**

Control amplifier must be installed according to manufacturer's instructions, and must comply with applicable local codes in a manner approved by the authority having jurisdiction. Refer to installation instructions packaged with control amplifier.

- 1 All signal wires connecting the Slot Sensor to the control and amplifier must be run separately from all other wiring. This is necessary to comply with intrinsic safety guidelines.

- 2 Use 2 conductor #18 twisted shielded cable, Belden 8760 or equivalent. For maximum protection, conduit is recommended.
- 3 Maximum cable length from meter to barrier must be less than 1,000 feet.
- 4 Module IS P.F. Control Amplifier KG30-T30/Ex or Equimeter Part #950757.
- 5 If meter is isolated, connect wire to earth ground. If meter is not isolated, do not connect green wire to ground.



A member of the BTR Group

## 2" and 3" TPL-9 TURBO METER WITH HIGH SPEED PULSER OUTPUT Pulse per Volume and Pulse Output Frequency Table

			STANDARD CONSTRUCTION				SPECIAL CONSTRUCTION			
Mechanical Output:			100 ft <sup>3</sup> /Rev.		1 m <sup>3</sup> /Rev.		10 ft <sup>3</sup> /Rev.		0.1 m <sup>3</sup> /Rev.	
Max. Capacity (ACFH):			9000 ACFH		255 m <sup>3</sup> /H		9000 ACFH		255 m <sup>3</sup> /H	
Chopper Disc Slots:			2 Slots		2 Slots		2 Slots		2 Slots	
External Gear Ratio:			10 to 1		10 to 1		1 to 1		1 to 1	
Turn Down Gear Ratio:			124.61538/1		41.53846/1		124.61538/1		41.53846/1	
Change Gears:			ENGLISH		METRIC		ENGLISH		METRIC	
Large	Small	Ratio	p/ft <sup>3</sup>	Hz	p/m <sup>3</sup>	Hz	p/ft <sup>3</sup>	Hz	p/m <sup>3</sup>	Hz
45-43T/26-26T	1.65385	41.219	103.047	1373.964	97.322	41.219	103.047	1373.964	97.322	
45-45T/26-27T	1.66667	41.538	103.846	1384.615	98.077	41.538	103.846	1384.615	98.077	
45-47T/26-28T	1.67857	41.835	104.588	1394.505	98.777	41.835	104.588	1394.505	98.777	
45-42T/26-25T	1.68000	41.871	104.677	1395.692	98.862	41.871	104.677	1395.692	98.862	
*45-44T/26-26T	1.69231	41.178	105.444	1405.917	99.586	41.178	105.444	1405.917	99.586	
45-46T/26-27T	1.70370	42.462	106.154	1415.385	100.256	42.462	106.154	1415.385	100.256	
45-48T/26-28T	1.71429	42.725	106.813	1424.176	100.879	42.725	106.813	1424.176	100.879	
45-43T/26-25T	1.72000	42.868	107.169	1428.923	101.215	42.868	107.169	1428.923	101.215	
45-45T/26-26T	1.73077	43.136	107.840	1437.870	101.849	43.136	107.840	1437.870	101.849	
45-44T/26-25T	1.76000	43.865	109.662	1462.154	103.569	43.865	109.662	1462.154	103.569	
45-46T/26-26T	1.76923	44.095	110.237	1469.822	104.112	44.095	110.237	1469.822	104.112	
45-48T/26-27T	1.77778	44.308	110.769	1476.923	104.615	44.308	110.769	1476.923	104.615	
45-43T/26-24T	1.79166	44.654	111.635	1488.458	105.432	44.654	111.635	1488.458	105.432	
45-45T/26-25T	1.80000	44.862	112.154	1495.385	105.923	44.862	112.154	1495.385	105.923	
45-47T/26-26T	1.80769	45.053	112.633	1501.775	106.376	45.053	112.633	1501.775	106.376	
46-49T/25-27T	1.81481	45.231	113.077	1507.692	106.795	45.231	113.077	1507.692	106.795	
45-44T/26-24T	1.83333	45.692	114.230	1523.077	107.885	45.692	114.230	1523.077	107.885	
45-46T/26-25T	1.84000	45.858	114.646	1528.615	108.277	45.858	114.646	1528.615	108.277	

\* Base Change Gear Set

**EXAMPLE:** (with BASE change gear set)

$$p/ft^3 = \frac{(\text{external gear ratio}) \times (\text{turn down ratio}) \times (\text{no. teeth large change gear}) \times (\text{no. disc slots})}{(\text{mechanical output}) \times (\text{number teeth small change gear})}$$

$$p/ft^3 = \frac{10 \times 124.61538 \times 44 \times 2}{100 \times 26} = \frac{109661.53}{2600} = 42.178 \text{ pulses/cubic foot}$$

$$Hz = \frac{p/ft^3 \times \text{maximum capacity}}{3600} = \frac{42.178 \times 9000}{3600} = 105.444 \text{ pulses per second}$$

### Periodic Inspection

The meter mechanism should be inspected periodically to ensure that all components are in good operating condition. The frequency of inspection is a function of the severity of the service.

The recommended inspection procedure is as follows:

1. Follow previously defined sequence for "SHUT-DOWN". Be sure all pressure in the meter has been relieved.
2. Remove mechanical readout device from the meter.
3. Disconnect pulser wiring. (If used.)
4. Remove two half-clamp bolts and half-clamps.
5. Carefully pull internal mechanism from body and place on clean surface.
6. Inspect meter body and nose cone.
7. Visually inspect rotor and shroud of the internal mechanism. A damaged rotor should be replaced.

8. While shielding the rotor from extraneous air currents, conduct a "Spin Test" of the mechanism using the following procedure:

- a. With a finger or air jet, forcibly spin the rotor.
  - b. Determine the time in seconds for the free-spinning rotor to come to a halt. Record this time.
  - c. Repeat this procedure three times and determine the average time in seconds obtained.
  - d. Compare the average spin time derived from tests to the table to the right.
9. If a satisfactory spin time for the application cannot be achieved after the rotor shaft bearings have been lubricated, replace the mechanism.
  10. Inspect top plate to body "O" ring and replace if necessary.
  11. Carefully insert mechanism into body, lining up the dowell pin on the top plate with the hole in the body flange. DO NOT FORCE.

12. Reposition half-clamps around top plate and body flange and attach bolts securely.
13. Remount readout device and reattach pulser wiring.
14. Pressurize meter following "START-UP" procedure previously described. Note: On high pressure installations, pressurize the meter slowly.
15. Check all joints for leaks.
16. Follow recommended lubrication procedure if not done during spin tests.
17. Following start-up, check the readout device for proper registration.

Stage of Assembly	Spin Time (Seconds)
Complete Assembly Less Readout	40
Less Intermediate Gear Assembly	42
Less Follower Magnet	46
Rotor Bearing and Bracket Assembly Only	55

## Proof Adjusting Turbo-Meters

Each Turbo-Meter is individually calibrated prior to shipment, using some of the most sophisticated calibration equipment in the world.

During the manufacturing process, individual meter component tolerances result in some scatter in initial meter proofs. As a result of the calibration procedures, these individual meter proofs are all brought into a band as close as possible to an absolute 100% accuracy.

To accomplish these minor shifts in meter proofs, paired change gears are used. These are precision machined gears which, in combination, provide exact mathematical ratios. Various gear combinations are used so that meter output shaft revolutions are in accurate engineering units.

A calibration curve including specific detail on the change gears installed is provided with each TPL-9 Turbo-Meter shipped.

For the 2" and 3" angle body meters (TPL-9 series) the change gears are mounted on top of the internal gear assembly (Figure 15).

The multiplying action of the change gears does not alter the basic configuration or shape of the basic meter proof curve. Instead, the entire curve is moved vertically in precisely known increments.

Because all Turbo-Meters are calibrated under controlled laboratory conditions, field replacement or substitution of alternate combinations of change gears is usually not necessary. Making unnecessary substitutions of change gears amounts to treating the symptoms rather than the cause of a proof shift in Turbo-Meters. The exception to this statement is substitution of a new rotor blade.

Replacement internal housing assembly measuring modules are shipped with their own change gears. When changing modules in the field, it is important to keep the change gear sets with their specific modules.

Change gears are individually stamped with two sets of numerical data. A large change gear for a 3" TPL-9 Turbo-Meter might be stamped "45-44T". The "45" relates to the gear blank size or diameter. The "44T" relates to the number of teeth on the gear.

Orders for change gears must specify both the blank size and number of teeth on the gear.

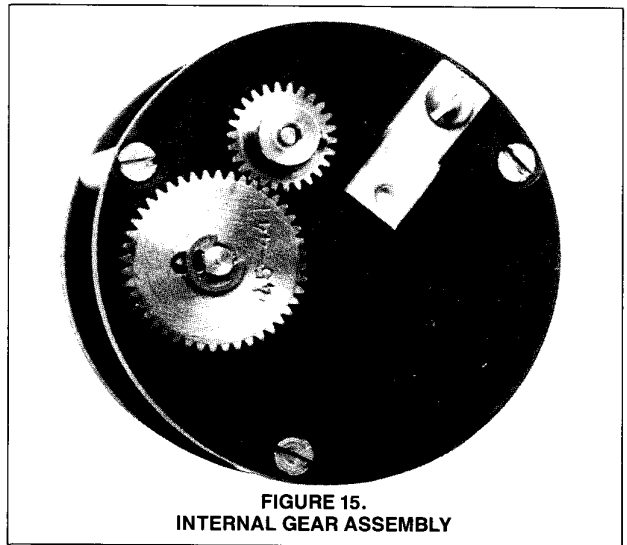
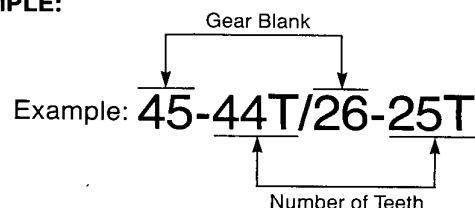

FIGURE 15.  
INTERNAL GEAR ASSEMBLY

**EXAMPLE:** Providing of a 3" TPL-9 Turbo-Meter with cubic foot output against an accurate reference standard indicates the meter is 0.75% slow. Inspection of the internal gear assembly reveals the gears are stamped "45-44T/26-26T". Reference to the change gear table indicates that switching to a "45-42T/26-25T" combination will speed up the meter proof by 0.73%, thereby bringing the meter into acceptable limits. Further reference to the table reveals that a shift to a "45-47T/26-28T" gear set would speed up the meter by  $(0.73 \text{ plus } 0.8) = \text{plus } 0.81\%$ .

**EXAMPLE:**





A member of the BTR Group

### 2" and 3" TPL-9 Turbo-Meters, Change Gears

#### Cubic Foot Output Meters

Item	Change Gear and Basic Blanks	Ratio	% of Change in Meter Registration
1	45-43T/26-26T	1.65385	0.77
2	45-45T/26-27T	1.66667	0.71
3	45-47T/26-28T	1.67857	0.08
4	45-42T/26-25T	1.68000	0.73
5	45-44T/26-26T	1.69231	0.67
6	45-46T/26-27T	1.70370	0.62
7	45-48T/26-28T	1.71428	0.33
8	45-43T/26-25T	1.72000	0.62
9	45-45T/26-26T	1.73077	

Base = 45-44T/26-26T

#### Cubic Meter Output Meters

Item	Change Gear and Basic Blanks	Ratio	% of Change in Meter Registration
1	45-44T/26-25T	1.76000	0.52
2	45-46T/26-26T	1.76923	0.48
3	45-48T/26-27T	1.77778	.78
4	45-43T/26-24T	1.79166	.46
5	45-45T/26-25T	1.80000	.43
6	45-47T/26-26T	1.80769	.39
7	46-49T/25-27T	1.81481	1.02
8	45-44T/26-24T	1.83333	.36
9	45-46T/26-25T	1.84000	

Base = 45-43T/26-24T

For additional information on Equimeter Turbo-Meters, please refer to the following Equimeter bulletins:

#### 2" and 3" TPL Turbo-Meters

Bulletin Number	Description
M-1080	General Description of TPL Turbo-Meters
MM-1080	Installation and Maintenance Instructions
MP-1080b	Parts List

#### 2" and 3" T-10 HP Turbo-Meters

Bulletin Number	Description
M-1083	General Description of T-10 HP Meters
MM-1083	Installation and Maintenance Instructions

#### 4", 6", 8" and 12" MARK II, AAT-II and PTB Turbo-Meters

Bulletin Number	Description
M-1070	General Description of MARK II Turbo-Meters
M-1072	General Description of PTB Turbo-Meters
MM-1070	Auto-Adjust II, MARK II and PTB Turbo-Meters Installation and Maintenance Instructions
MP-1070a	4" T-18 Turbo-Meter Parts Lists
MP-1070b	6" T-30 Turbo-Meter Parts Lists
MP-1070c	8" T-60 Turbo-Meter Parts Lists
MP-1070d	12" T-140 Turbo-Meter Parts Lists
M-1073	General Description of Auto-Adjust II
MP-1073a	AAT-18 Parts List
MP-1073b	AAT-35 Parts List
MP-1073c	AAT-60 and AAT-90 Parts List
MP-1073d	AAT-140 Parts List
MP-1073e	AAT-18 Parts List

### Summary

Under normal conditions, it should not be necessary to change the original calibration of a Turbo-Meter unless it becomes necessary to replace a critical part such as a rotor. Normal operating factors such as drag in the rotor shaft bearings should be corrected by lubrication or, if necessary, bearing replacement.

It is necessary to maintain good records on the calibration data of each large volume meter. The original units purchased are each shipped with a calibration curve on which the actual accuracy and spin times of that specific meter are precisely defined. These original records should be held on file along with any subsequent calibration or spin time data developed for that meter.

**LIMITED WARRANTY** Seller warrants the Goods to be free from defects in materials manufactured by Seller and in Seller's workmanship for a period of [one (1) year] after tender of delivery (the "Warranty Period"). **THIS LIMITED WARRANTY (a) IS IN LIEU OF, AND SELLER DISCLAIMS AND EXCLUDES, ALL OTHER WARRANTIES, STATUTORY, EXPRESS OR IMPLIED, INCLUDING, WITHOUT LIMITATION, ANY WARRANTY OF MERCHANTABILITY OR FITNESS FOR A PARTICULAR PURPOSE, OR OF CONFORMITY TO MODELS OR SAMPLES;** (b) does not apply to any Goods which have been (i) repaired, altered or improperly installed; (ii) subjected to improper use or storage; (iii) used or incorporated with other materials or equipment, after Buyer or anyone using the Goods has, or reasonably should have, knowledge of any defect or nonconformance of the Goods; or (iv) manufactured, fabricated or assembled by anyone other than Seller; (c) shall not be effective unless Buyer notifies Seller in writing of any purported defect or nonconformance within [thirty (30) days] after Buyer discovers or should have reasonably discovered such purported defect or nonconformance; and (d) shall only extend to Buyer and not to any subsequent buyers or users of the Goods. Buyer shall provide Seller access to the Goods as to which Buyer claims a purported defect or nonconformance; upon request by Seller, Buyer shall, at its own risk and expense, promptly return the Goods in question to Seller's Plant.



805 Liberty Boulevard  
P.O. Box 528  
DuBois, Pennsylvania 15801  
**(814) 371-8000**  
FAX (814) 375-8460

Printed in USA  
NUPP/97, 10M

A member of the BTR Group